

ER Multipoint II Çok Noktalı Topraklama Sistemi

İngilizce - Türkçe

Datasheet - Doküman

Earth-Rite® MULTIPOINT II

Static Grounding System



Earth-Rite MULTIPOINT II Static Grounding System

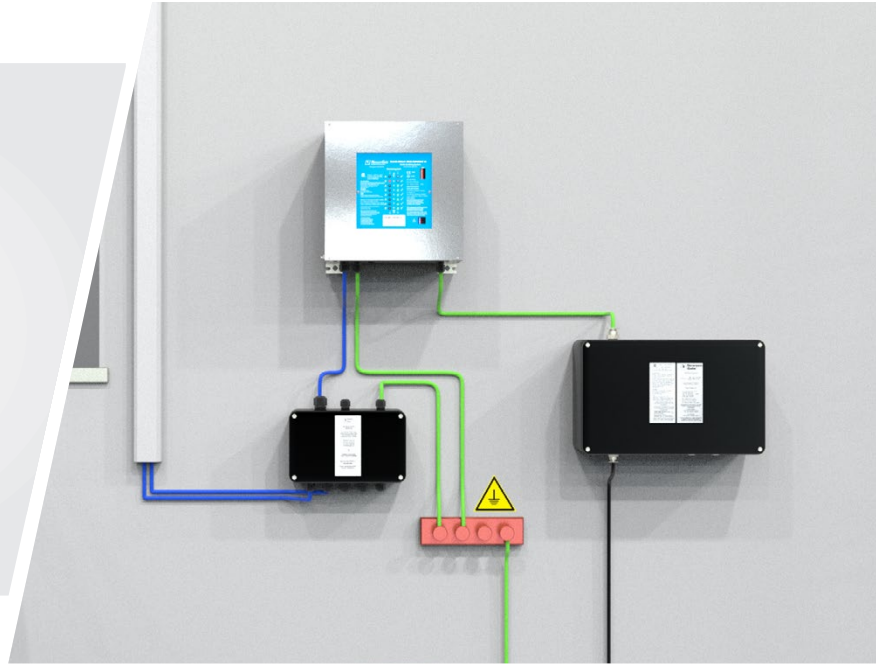

To ground and monitor multiple items of equipment at points like multi drum loading stations and mixing stations, IBC loading stations and railcar loading gantries, a large number of conventional static grounding systems would be required to minimize the accumulation of static electricity. In addition to flammable liquid and gas operations, powder processing equipment that typically includes interconnected pipes, fluid bed dryers, hoppers and micronizers would require multiple grounding systems. With the Earth-Rite® MULTIPOINT II up to eight individual items of potentially isolated equipment can be ground monitored simultaneously with a single static grounding system.

The Earth-Rite MULTIPOINT II is an ATEX / IECEX / cCSAus certified static grounding system which identifies when equipment exceeds ground resistance levels outlined in recommended practice documents like IEC TS 60079-32-1 and NFPA 77.

The system consists of a hazardous area monitoring unit that contains eight pairs of red and green LED indicators that verify when the equipment at risk of static charge accumulation has a resistance of 10 Ohms or less to the plant's designated true earth grounding point.

For applications where ground monitoring indication is required at the point of operation (e.g. drum filling) local ground status indicator stations can be specified.

Each monitoring channel interfaces with it an individual volt free contact as standard. In addition to the 8 individual volt free contacts a group relay is provided so that multiple ground monitoring channels can be setup to provide a permissive / non-permissive condition to external equipment (e.g. PLCs, pumps, valves, sounders).

Earth-Rite MULTIPOINT II applications include:

- multiple railcar loading points
- multiple drum / tote loading points
- liquid / powder mixing and blending
- powder conveying equipment
- fluid bed dryers
- silo / container filling and emptying
- hoppers and dust collectors
- powder micronizing, pulverising and grinding equipment

Earth-Rite® MULTIPOINT II

Static Grounding System

Earth-Rite® MULTIPOINT II



The Earth-Rite MULTIPOINT II's monitoring unit contains 8 pairs of LED ground status indicators (red and green).

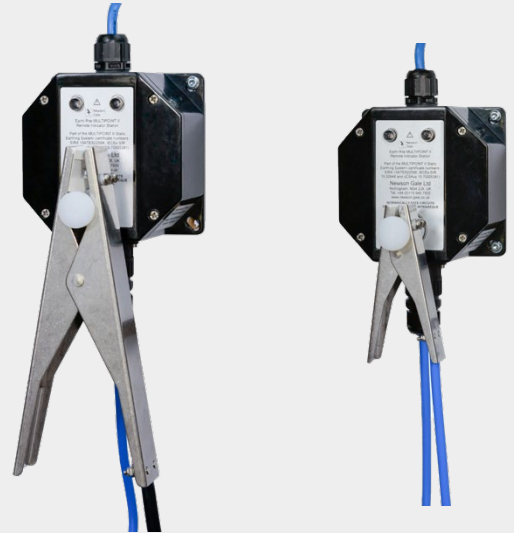

The Earth-Rite MULTIPOINT II's energy efficient remote indicator stations provide ground status indication for each individual channel. The attention grabbing high intensity GREEN LED pulses continuously when a positive ground connection is made.



The Earth-Rite MULTIPOINT II's 230 V/110 V AC power supply unit houses eleven (11) SP/DT volt free contacts. 8 of these interface with each monitored grounding channel, 2 provide the grouped channel function and 1 relay provides the fail-safe redundancy output function.



The Earth-Rite MULTIPOINT II's 4 way and 8 way marshalling junction boxes link the monitoring unit with the external ground connection points and external LED ground status remote indicator stations. The marshalling boxes can be supplied as GRP and stainless steel.

Earth-Rite® MULTIPOINT II

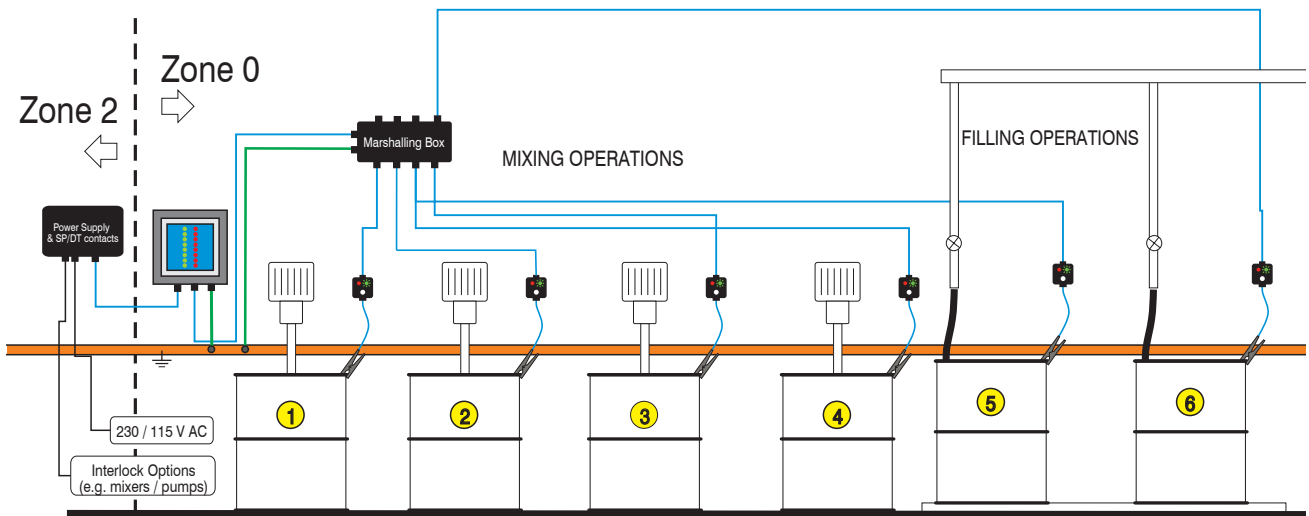

The Earth-Rite MULTIPOINT II's monitoring unit and power supply can be configured to ground and monitor a wide range of equipment. In this example the system is setup to ground four mixing stations (1 to 4) and two filling stations (5 and 6). Each mixer is interlocked with an individual relay corresponding to the equivalent ground monitoring channel. Channels 5 and 6 are grouped via the group relay so that if either drum is not grounded the pump feeding the filling station is shut down immediately, thereby mitigating the build up of static on the drums.

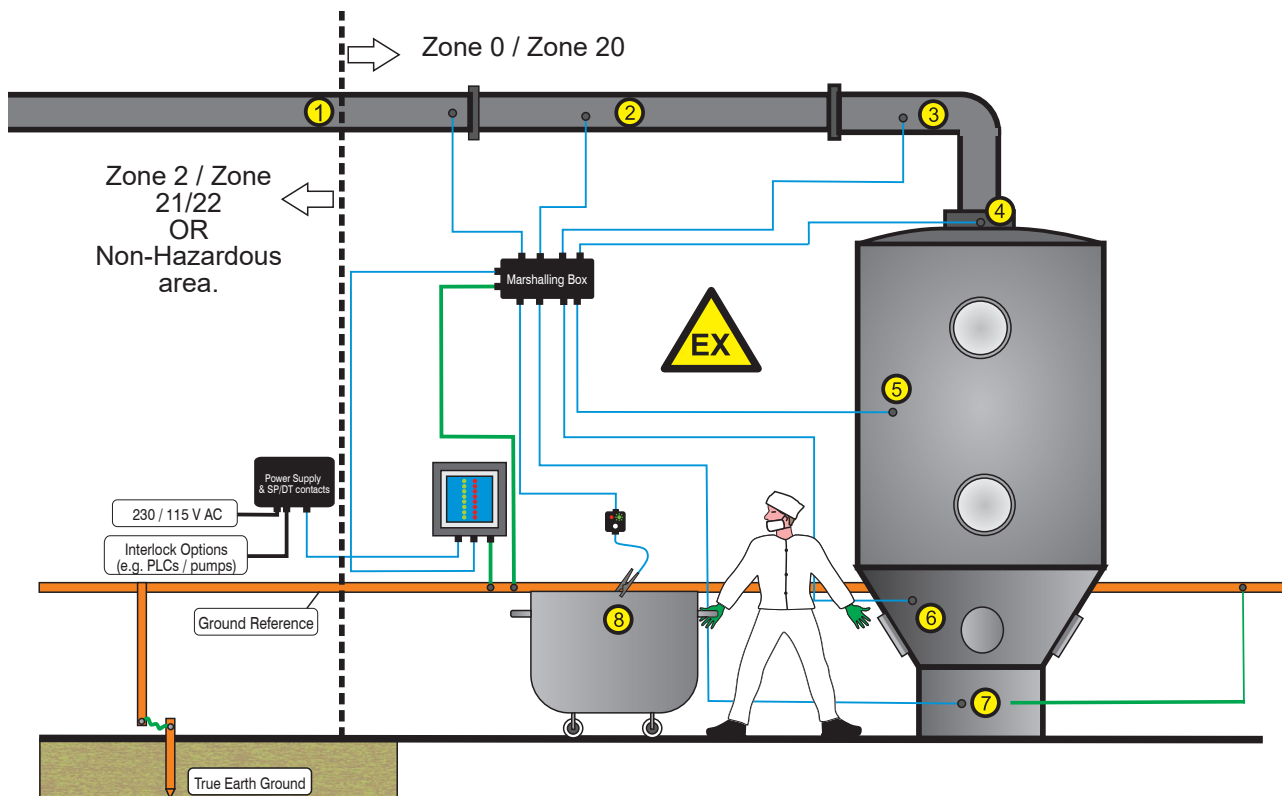

In this example the Earth-Rite MULTIPOINT II is configured to ground multiple interconnected components for a fluid bed dryer system. The marshalling box feeds seven channels out to seven permanent ground connection points [the connection points may be disconnected for routine cleaning, inspection and maintenance]. Channels 1 to 7 are grouped together to provide a single output contact controlling the flow of powder into the fluid bed dryer. Channel 8 utilises an external ground status LED remote indicator station/ clamp/cable to provide the operator with a visual confirmation that the mobile bin is grounded when filled.

Earth-Rite® MULTIPPOINT II

Technical Specification

(with GRP power supply)

Monitoring unit

Zone 0/20 Installations

Ambient Temperature Range	-40°C to +60°C
Ingress Protection	IP 66
Construction	Stainless Steel (SS grade: 304)
Monitoring Circuit	Intrinsically safe
Monitoring Loop Resistance	Nominally $\leq 10 \text{ Ohm}$ ($\pm 10\%$)
Cable Entries	3 x M20, 1 x M25

Power Supply Unit

Zone 2/21 Installations

Power Supply	115 V or 230 V AC, 50-60 Hz
Current Rating	200 mA
Power Rating	10 Watts
Ambient Temperature Range	-40°C to +60°C
Ingress Protection	IP 66
Construction	GRP with carbon loading
Output to Monitoring Unit	Intrinsically safe
Output Channel Relay	8 off Voltage free change over switch contacts
Output Group Relay	2 off Voltage free change over switch contacts
Output Fault Relay	1 off Voltage free change over switch contacts
Relay Contact Rating	240 V AC, 5 A, 500 VA max resistive 30 V DC, 2 A, 60 W max resistive
Cable Entries	12 x M20

Marshalling Junction Box

Enclosure Material	GRP with carbon loading
Cable Entries	8 Way - 10 x M20, 1 x M25 4 Way - 6 x M20, 1 x M25

Remote Indicator Station

Associated Apparatus - Zone 0/20 installation

Enclosure Material	GRP with carbon loading
Cable Entries	1x M20

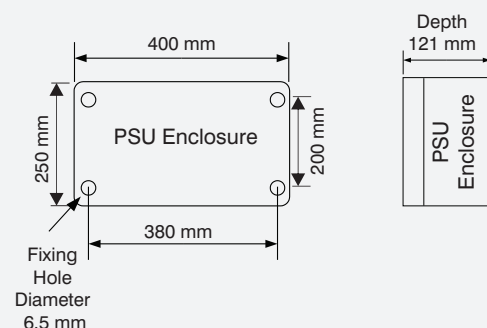
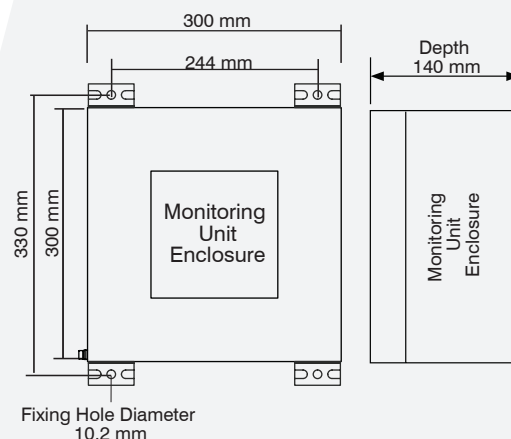

Product Description	Length	Height	Depth
8-Way Junction Box	259 mm	160 mm	91.4 mm
4-Way Junction Box	160 mm	160 mm	94 mm
Remote Indicator Station	122 mm	122 mm	76.2 mm
Junction Box with Stowage Pin	80 mm	76.2 mm	55.9 mm

For more detailed mechanical descriptions please refer to instruction manual

Earth-Rite® MULTIPOINT II

Technical Specification

(with stainless steel power supply)

Monitoring unit

Zone 0/20 Installations

Ambient Temperature Range	-40°C to +60°C
Ingress Protection	IP 66
Construction	Stainless Steel (SS grade: 304)
Monitoring Circuit	Intrinsically safe
Monitoring Loop Resistance	Nominally $\leq 10 \text{ Ohm}$ ($\pm 10\%$)
Cable Entries	3 x M20, 1 x M25

Power Supply Unit

Zone 2/21 Installations

Power Supply	115 V or 230 V AC, 50-60 Hz
Current Rating	200 mA
Power Rating	10 Watts
Ambient Temperature Range	-40°C to +60°C
Ingress Protection	IP 66
Construction	Stainless Steel (SS grade: 304)
Output to Monitoring Unit	Intrinsically safe
Output Channel Relay	8 off Voltage free change over switch contacts
Output Group Relay	2 off Voltage free change over switch contacts
Output Fault Relay	1 off Voltage free change over switch contacts
Relay Contact Rating	240 V AC, 5 A, 500 VA max resistive 30 V DC, 2 A, 60 W max resistive
Cable Entries	12 x M20

Marshalling Junction Box

Enclosure Material	Stainless Steel (SS grade: 304)
Cable Entries	8 Way - 10 x M20, 1 x M25 4 Way - 6 x M20, 1 x M25

Remote Indicator Station

Associated Apparatus - Zone 0/20 installation

Enclosure Material	Stainless Steel (SS grade: 304)
Cable Entries	1x M20

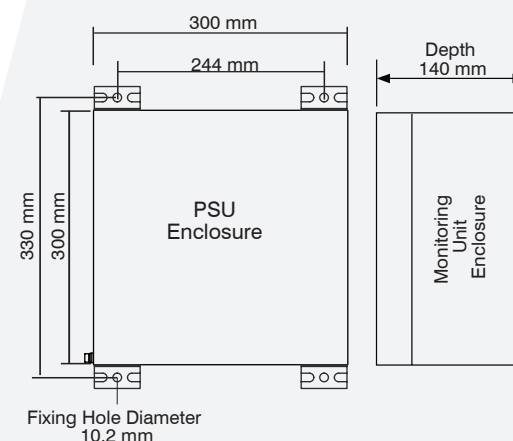
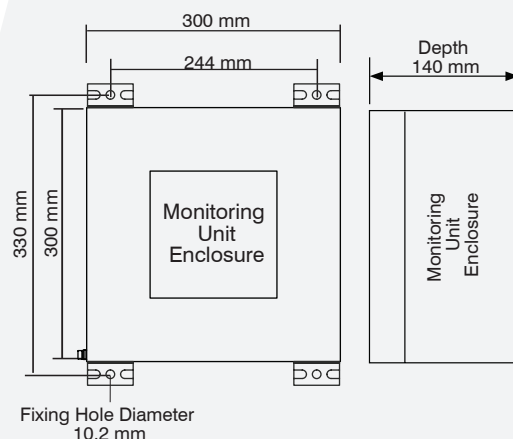

Product Description	Length	Height	Depth
8-Way Junction Box	300 mm	200 mm	81 mm
4-Way Junction Box	150 mm	150 mm	81 mm
Remote Indicator Station	150 mm	150 mm	81 mm
Junction Box with Stowage Pin	150 mm	150 mm	81 mm

For more detailed mechanical descriptions please refer to instruction manual

Earth-Rite® MULTIPOINT II

Hazardous Area Certification

Monitoring Unit

Europe / International:

North America Version Available:

IECEX

Ex ia IIC T4 Ga
Ex ia IIIC T135°C Da
Ta = -40°C to +60°C
IECEX EXV 19.0062X
IECEX Certifying Body: ExVeritas

NEC 500 / CEC (Class & Division)

Suitable for use In
Class I, Div. 2, Groups A, B, C, D
Class II, Div. 1, Groups E, F, G
Class III, Div. 1
Provides intrinsically safe output for
Class I, Div. 1, Groups A, B, C, D;
Class II, Div. 1, Groups E, F, G
Class III, Div. 1;
When installed per Control Dwg;
X MPII Q15152
Ta = -40°C to +60°C (-40°F to +140°F)

ATEX

Ex ia IIC T4 Ga
Ex ia IIIC T135°C Da
Ta = -40°C to +60°C
ExVeritas 19ATEX0546X
ATEX Notified Body: ExVeritas

OSHA recognised NRTL: CSA
CSA 15.70005381

NEC 505 & 506 (Class & Zoning)

Class I, Zone 2, AEx nA[ia Ga] nC IIC T4 Gc
(Gas & vapour)
Class II, Zone 21, AEx tb IIIC T65°C Db
(Combustible Dusts)

CEC Section 18 (Class & Zoning)

Ex nA[ia Ga] nC IIC T4 Gc
Ex tb IIIC T65°C Db

Power Supply Unit

Europe / International:

North America Version Available:

IECEX

Ex ec[ia Ga] nC IIC T4 Gc
Ex tb IIIC T65°C Db
Ta = -40°C to +60°C
IECEX EXV 19.0062X
IECEX Certifying Body: ExVeritas

NEC 500 / CEC (Class & Division)

Suitable for use In
Class I, Div. 2, Groups A, B, C, D
Class II, Div. 1, Groups E, F, G
Class III, Div. 1
Provides intrinsically safe output for
Class I, Div. 1, Groups A, B, C, D;
Class II, Div. 1, Groups E, F, G
Class III, Div. 1;
When installed per Control Dwg;
X MPII Q15152
Ta = -40°C to +60°C (-40°F to +140°F)

ATEX

Ex ec[ia Ga] nC IIC T4 Gc
Ex tb IIIC T65°C Db
Ta = -40°C to +60°C
ExVeritas 19ATEX0546X
ATEX Notified Body: ExVeritas

OSHA recognised NRTL: CSA
CSA 15.70005381

NEC 505 & 506 (Class & Zoning)

Class I, Zone 2, AEx nA[ia Ga] nC IIC T4 Gc
(Gas & vapour)
Class II, Zone 21, AEx tb IIIC T65°C Db
(Combustible Dusts)

CEC Section 18 (Class & Zoning)

Ex nA[ia Ga] nC IIC T4 Gc
Ex tb IIIC T65°C Db

Additional Certification

EMC Tested:

to EN 61000-6-2, EN 61000-6-3
FCC - Part 15

System Options

2-Pole Surface Mountable connector

With this assembly operators tasked with earthing mobile process equipment will have a dedicated earthing point to attach the easy to use screw thread connector. The 'plug and play' connector can interface with all Newson Gale 2 core systems to provide earth monitoring capability on a wide range of mobile processes and equipment where generic earthing clamps cannot be used.

The conical shape design aids in the reduction of powder deposit build up over time and aids in clean down operations.

- Made using Stainless Steel (SS grade: 304) with Viton O-Rings
- IP 66
- -40°C to 60°C
- Various lengths of straight or spiral Hytrel cable available.
- IECEx Ex h Certification:

Ex h IIC T6 Ga
Ex h IIIC T85°C Da
Ta = -40°C to +60°C
IECEX EXV 20.0033



Copyright Notice

The website and its content is copyright of Newson Gale Ltd © 2020. All rights reserved.

Any redistribution or reproduction of part or all of the contents in any form is prohibited other than the following:

- you may print or download to a local hard disk extracts for your personal and noncommercial use only
- you may copy the content to individual third parties for their personal use, but only if you acknowledge the website as the source of the material

You may not, except with our express written permission, distribute or commercially exploit the content. Nor may you transmit it or store it in any other website or other form of electronic retrieval system.

Right to change

This document provides general information only and may be subject to change at any time without notice. All information, representations, links or other messages may be changed by Newson Gale at any time without prior notice or explanation.

Newson Gale is not obliged to remove any outdated information from its content or to expressly mark it as being outdated. Please seek the advice of professionals as necessary regarding the evaluation of any content.

Disclaimer of liability

The information provided in this Datasheet is provided by Newson Gale without any representations or warranties, expressed or implied, as to its accuracy or completeness. The liability of Newson Gale for any expenses, losses or actions incurred whatsoever by the recipient as a result of the use of this Datasheet shall be excluded.

Leading the way in hazardous area static control

www.newson-gale.com

7/7

United Kingdom
Newson Gale Ltd
Omega House
Private Road 8
Colwick, Nottingham
NG4 2JX, UK
+44 (0)115 940 7500
groundit@newson-gale.co.uk

United States
IEP Technologies LLC
417-1 South Street
Marlborough, MA 01752
USA
+1 732 961 7610
groundit@newson-gale.com

Deutschland
IEP Technologies GmbH
Kaiserswerther Str. 85C
40878 Ratingen
Germany
+49 (0)2102 58890
erdung@newson-gale.de

EARTH- RITE MULTIPOINT II ÇOK NOKTALI STATİK TOPRAKLAMA SİSTEMİ

Bu sistemdeki tek bir ünite, tehlikeli bölgedeki 8 ayrı noktaya bağlanıp, topraklamanın devamlılığının izlenmesini sağlar.



Ana ünite ve dağıtım kutusu Zone 0/1/20'e, Güç kaynağı ve Çıkış Kontakları Kutusu Zone 2/21/22 veya güvenli bölgeye monte edilir. Sistem, her bir noktaya gönderdiği ayrı bir (IS) sinyal ile topraklama direncinin 10 ohm'un altında kalıp kalmadığını denetler (CLC/TR 60079-32-1 ve NFPA 77'e göre). Bu direncin aşılması durumunda ana ünitenin üzerindeki yeşil ışık kırmızıya döner, görsel sinyalin alınmasının yanı sıra, alınan çıkış kullanılarak proses kontrolü sağlanabilir.

Bu sistem iki farklı amaç için kullanılabilir:

1) Hareketli tanklar, karıştırıcılar veya sabit tanklar, boru hatları vb. yerlerde oluşabilecek iletkenliğin kesilmesi ve izole edilmiş bölümlerin ortaya çıkmasını önlemek:

Bu tip iletkenliğin kesilmesi durumlarında izole edilmiş bölgede oluşan statik elektrik arka ve patlamaya neden olabilir. ER Multipoint II Sistemi ile bu tehlike oluşmadan müdahale imkânı doğar.

2) Birden fazla dolum-boşaltım operasyonu olan geniş sahalarda tek bir sistem ile güvenli topraklama yaparak kontrol sağlanabilir ve ekonomik çözüm üretilebilir.

Sistem projeye uygun olarak geniş bir sahada kullanılabilir. Opsiyonel olarak lokal görsel ikaz lambaları da temin edilebilir.

Sistem, EEx ia IICT4 koruması ile Zone 1 ve Zone 2 hatta Zone 0 tehlikeli bölgelerinde kullanıma ve EC Avrupa normlarına uygundur.

Kullanılabilecek Alanlar:

- 1) Birden fazla vagon dolum-boşaltım noktası
- 2) Birden fazla varil ve/veya IBC dolum-boşaltım noktası
- 3) Sıvı-toz karıştırıcılar
- 4) Akışkan yataklı kurutucular
- 5) Silo/konteyner doldurma-boşaltma
- 6) Toz haline getirme ve öğütme ekipmanları
- 7) Toz taşıma ekipmanları